



# Car Transporter



# In safe hands

Since 1958, people have put their trust in our trailers, just ask an owner - they're not difficult to find. As specialists in trailer design and engineering, we have continued to set the standard both in the UK and throughout much of Europe. We are an independent company with one focus: to build the best products on the market. More than 30,000 people choose our trailers each year - but we're not standing still. Our dedicated investment in new technologies and materials ensures that our products continue to exceed the expectations of our customers. We know that quality, strength, value and ease of maintenance are of vital importance to you. That's why we've made them the driving force behind everything we do.



# Transporter Trailers

Take a look at any of our trailers and you'll find that safety, flexibility and ease of use are included as standard. The new transporter range is no exception, providing a robust and reliable vehicle-carrying solution for motorsports enthusiasts, hire firms and motor trade professionals.

## Engineering matters

With a trailer that is being used on a regular basis it pays to have one designed and engineered specifically for the task. Optimised using design and analysis software and tested on our fatigue testing rig, we believe that this range of transporters meets the needs of even the most demanding user.

## Stability when towing

All our transporters feature an exclusive beam axle and leaf spring suspension system which has been developed for a safe and stable ride. Similar systems are widely used on commercial vehicles, where performance under load is essential. Renowned for its durability and ease of maintenance, the Ifor Williams beam axle system contributes significantly to the low depreciation of our trailers.

## Moving anything on wheels

Alongside our well known Beavertail and Tiltbed trailers, our new vehicle transporters offer even more flexibility and durability. This all adds up to an exceptionally versatile trailer line-up giving you the ability to carry almost anything on wheels!

## Minimal upkeep - built to last

The galvanized steel construction offers unbeatable corrosion protection. All our trailers are security marked with visible and covert markings to deter the would-be thief and every detail is specified for top performance and a long, trouble-free life.

A silver Volkswagen car is being loaded onto a transporter trailer. A worker in a blue uniform and a high-visibility yellow vest is using a manual winch to secure the car. The trailer is parked on a paved road next to a grassy area with trees and hills in the background.

CT177 With optional manual winch



CT177 in tilt position with optional winch

# CT177

## CT177 Transporter

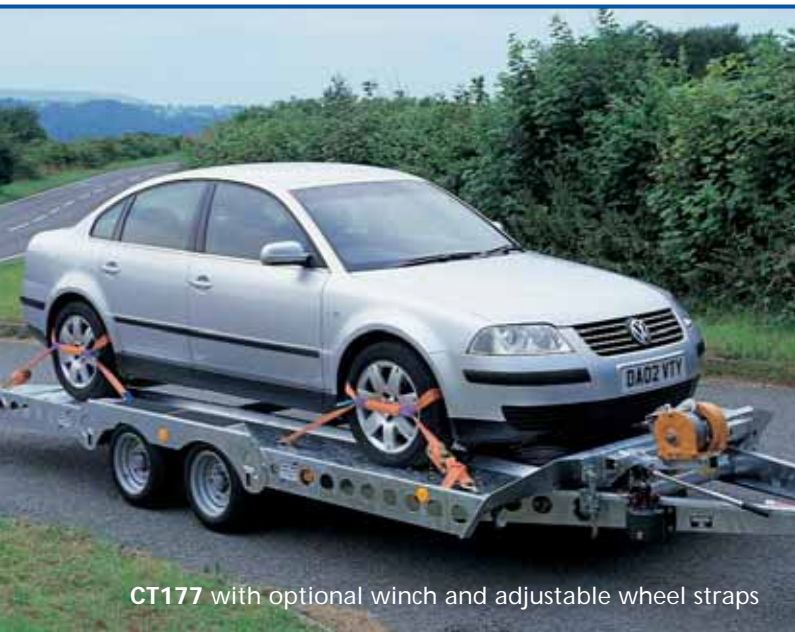

CT177 with optional winch and adjustable wheel straps



CT177 in tilt position with optional winch



CT177 with optional winch

A versatile transporter, wide enough for most light commercials and narrow enough for the smaller car, the CT177 is the ideal trailer for the motor trade or hire professional. Its tilt bed action combined with pull out mini-skids allows for quick and efficient loading of vehicles either under their own power or using one of the winch options available.

The combination of optimum engineering design and high strength materials has produced a trailer with an excellent strength to weight ratio.

Wheel arch tops are only 10cm (4") from the bed to give ample door clearance and feature high grip treads for safe entry and exit from the vehicle being carried. The optional heavy duty wheel straps feature a soft-link that will not damage expensive alloy wheels and can be stowed away in the built-in toolbox.

Mini-skids, to give improved ground clearance, can be quickly and easily slid into position. Fully retained at all times they cannot be lost or stolen and once the vehicle is loaded they simply slide back in place within the rear deck.

The removable winch arm is fully adjustable from side to side allowing alignment with off-centre vehicle recovery eyes.

A range of winch options further enhance the trailer specification and the optional centre deck section fills three quarters of the centre deck area to provide a safe walk-on platform as an alternative to the open centre.

**Standard features include:**

- 50mm ball coupling with lockable head
- Retained pull-out mini skids
- Adjustable winch arm and mounting rail
- Hydraulic tilting system
- Fold-out rear lights
- Heavy duty jockey wheel
- Spare wheel recessed into trailer deck
- Lockable toolbox

**Optional features include:**

- Softlink adjustable wheel straps
- Centre deck section fills
- Selection of winches

# CT177

## Standard Dimensions

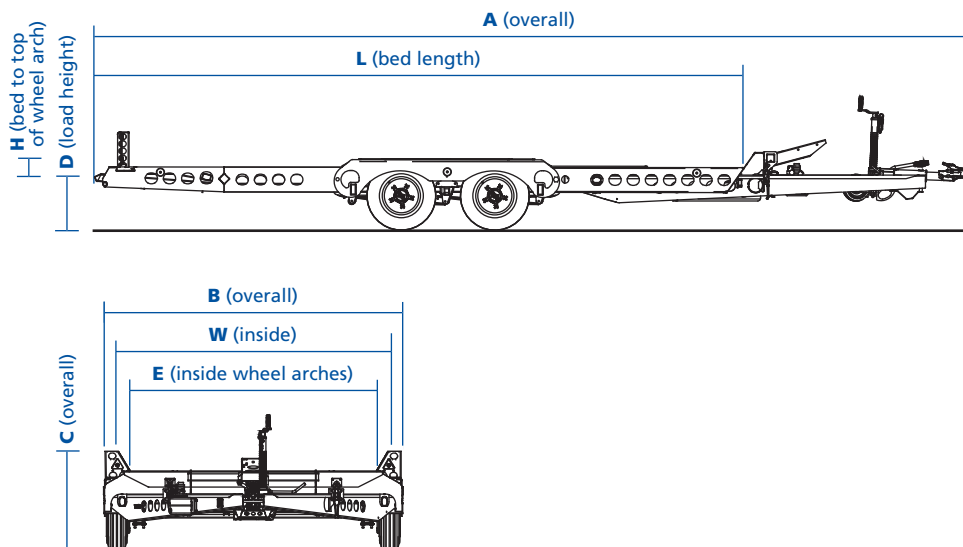

Dimensions in metres	A	B	C	D	E	L	W	H	Unladen weight	Gross weight
CT177	6.7	2.3	0.75	0.43	1.91	5.0	2.2	0.1	805kg	3500kg



# CT177

## Standard Features



### Coupling Head

The lockable low-profile coupling head ensures optimum clearance of 4x4 rear doors (also standard on CT136HD).

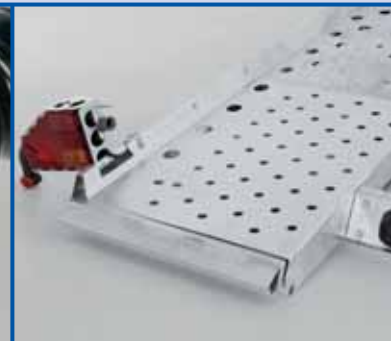

### Mini Skids

Retained mini-skids for additional ground clearance, ideal for low clearance vehicles. Skids are kept in place by a steel peg located underneath the rear light clusters.



### Fitted Spare Wheel and Lockable Toolbox

Concealed neatly below the deck level, both are included as standard (optional GM5 winch shown).



### Sliding Winch Bracket

With the optional winch fitted on the bracket the whole assembly can move from side to side to allow for variation in vehicle towing eye position. The winch bracket can be removed so valuable winch equipment can be locked away securely.



# CT177 Options



## Fold-out Adjustable Rear Light Clusters

Rear light clusters fold out to allow wider vehicles access up ramps (lights should not be adjusted on public highways).

## Perforated Platform

The whole of the trailer platform is perforated to provide both traction and multiple lashing positions.

The addition of selected accessories allows you to further enhance your transporter, and tailor it to suit your specific needs.

## Heavy Duty Wheel Straps

Heavy duty wheel securing straps incorporating soft-link to avoid damage to alloy wheels.

## GM5 Heavy Duty Strap Winch (mechanical) - see Sliding Winch option opposite

High quality all ball bearing winch with fast spool and rewind action and wide webbing strap.

## 3T Strap Winch (mechanical)

Standard 3 tonne rated mechanical winch fitted with webbing strap.

## 3T Cable Winch (mechanical)

Standard 3 tonne rated mechanical winch fitted with steel cable.

## E40 Cable Winch (electric)

Electric winch supplied with hand held remote control and power leads, available in 12v and 24v versions. Also available with on board battery.

## Centre Decking

Provides a safe walk on platform as an alternative to the open centre. Load rating of platform 300 Kg/m<sup>2</sup>. Covers 3/4 of trailer bed.



Heavy duty wheel straps



Centre decking



## Uncoupled Loading

A special skid under the coupling allows the trailer to be loaded when uncoupled. This avoids overloading the towing vehicle towball when loading heavier vehicles.

## Galvanized Construction & Hydraulic Tilt System

Galvanized steel deck and drawbar constructed from high tensile steel for maximum strength to weight ratio. Quick release fasteners and hydraulic system combine to save valuable time when loading.

## Heavy Duty Wheel Arches

Steel wheel arches can be driven over by larger vehicles if necessary and provide a secure footstep.

All winch options have an automatic brake, preventing the vehicle from rolling back if the winch handle is released whilst loading or unloading.

# CT115 & CT136 Transporter

# CT115 & CT136

With four models available, both vehicle recovery and motor sport are catered for within these trailer ranges. Twin high tensile galvanized steel structures are mounted on the exclusive Ifor Williams beam axle suspension and combine to give a versatile, strong and easy to use vehicle carrier.

Utilising the same lightweight construction on all four models, the single axle CT115 & CT136 (1400kg gross), twin axle (2000kg gross) and heavy duty (2600kg gross) models are lightweight trailers giving a maximum payload capacity of 1000kg, 1500kg and 2100kg respectively.

The optional removable / adjustable front wheel chocks take the guess work out of positioning your vehicle. The heavy duty wheel straps (conveniently stored in the lockable toolbox) can be anchored at any number of perforations provided in the bed.

Detachable loading skids and rear steady legs allow the trailer to be stabilised at the perfect clearance angle. The loading skids stow quickly, conveniently and securely within the bed area.

A winch mounting bar, bracket and a range of winches can be added to aid vehicle recovery. Whilst for motorsport users a front mounted tyre rack option can be fitted with straight or cranked restraining bar to suit the same or different sized tyre combinations. An optional motorcycle recovery kit allows even more functionality, with enough space to carry a large motorcycle securely (CT136TA and CT136HD only).

#### Standard features include:

- Adjustable rear steady legs
- 2m long loading skids
- Impact resistant plastic mudguards
- Lockable coupling head
- Heavy duty jockey wheel

#### Optional features include:

- Lockable spare wheel and carrier
- Adjustable front wheel chocks
- Lockable toolbox
- Softlink adjustable wheel straps

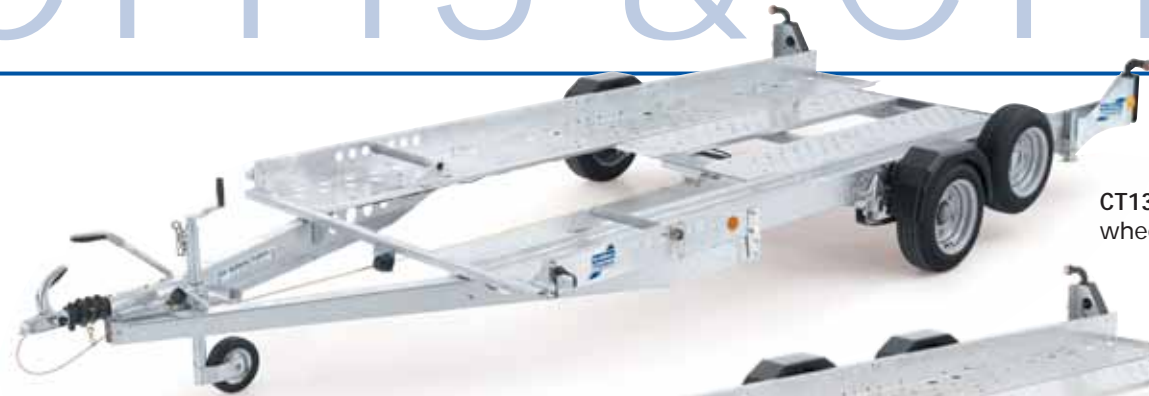

CT136SA single axle with spare wheel and wheel chocks

CT115 Single Axle

CT136 Single Axle

CT136 Twin Axle

CT136 Heavy Duty



CT136TA twin axle with spare wheel and wheel chocks

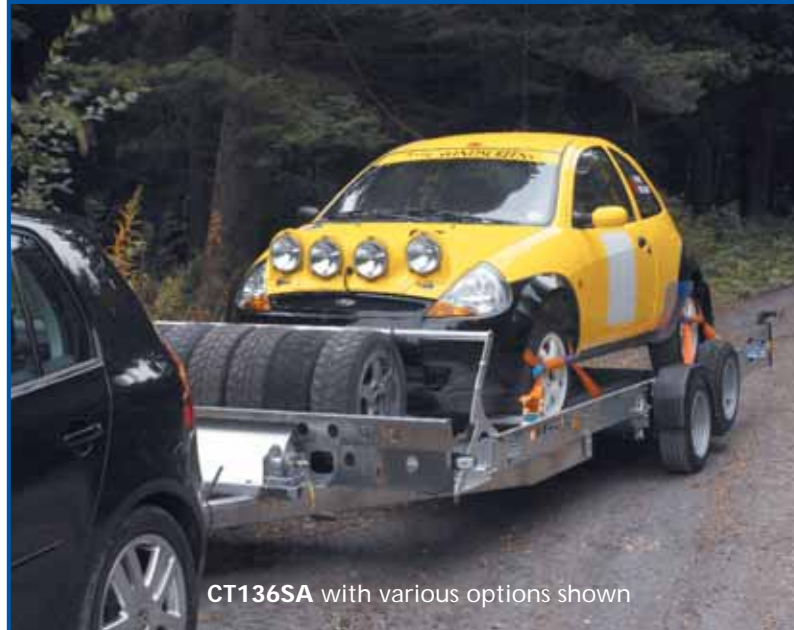

CT136SA with various options shown



CT136TA with various options shown



CT136SA with optional toolbox in uncoupled loading mode (see features page)

# CT115 & CT136

## Standard Dimensions

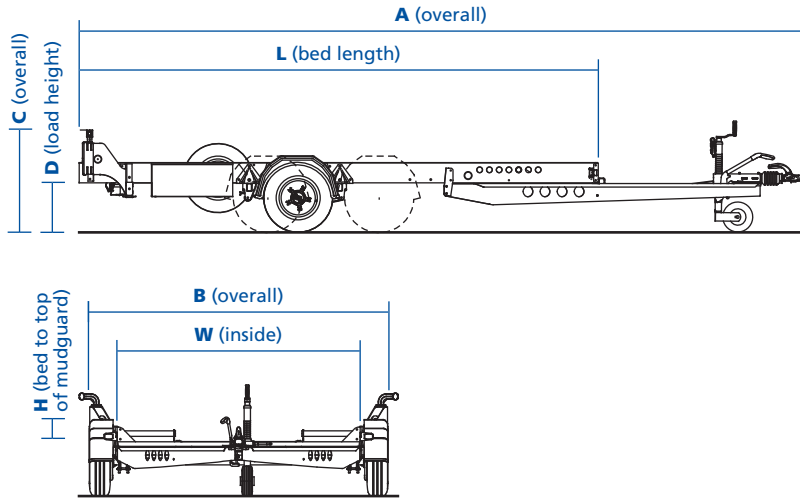

Dimensions in metres	A	B	C	D	L	W	H	Unladen weight	Gross weight
CT115 (single axle)	5.06	2.15	0.79	0.39	3.5	1.7	0.2	350kg	1400kg
CT136SA (single axle)	5.56	2.3	0.79	0.39	4.0	1.86	0.2	400kg	1400kg
CT136TA (twin axle)	5.56	2.3	0.79	0.39	4.0	1.86	0.2	495kg	2000kg
CT136HD (twin axle)	5.56	2.3	0.79	0.39	4.0	1.86	0.2	500kg	2600kg



CT136SA with various options

# CT115 & CT136

## Standard Features (single & twin axle)



### Uncoupled Loading Mode

To allow low ground clearance vehicles to be loaded without the need for a tilt mechanism.



### Loading Skids

The loading skids are readily accessible at the point of use. Skids are retained by the number plate holder.

Simply release and fold down...

...and slide the skid out from its location.

# CT115 & CT136 Options



## Support Leg

Adjustable rear support leg.



## Low Profile Mudguards

At less than 200mm between the bed and the top of the mudguard, the low profile mudguard allows ample clearance for most car doors.



## Coupling Head

The lockable coupling head can be locked on or off the coupling for additional security. Available on CT115, CT136SA and CT136TA only. See CT177 standard features for CT136HD coupling head. (Padlock not included).



Skids suitable for normal loading or uncoupled loading mode.



Lights are positioned well clear of the trailer body.



Skids do not protrude beyond the trailer deck, and can be refitted beneath the lowest of vehicles.

The addition of selected accessories allows you to further enhance your transporter, and tailor it to suit your specific needs.

## Winch Options\*

Circuit 600kg mechanical cable winch.  
Rally 1050kg mechanical cable winch.  
Recovery 1500kg mechanical cable winch.

## Winch Mounting Kit - required with Winch option above

Mounting bar and winch mounting bracket allows winch to be fitted in left or right hand mounting positions.

## Tyre Rack - Straight Bar (see opposite)

Mounted to the front of the trailer this adjustable rack can accommodate a set of wheels / tyres ranging from 500mm to 650mm in diameter

## Tyre Rack - Cranked Bar

Mounted to the front of the trailer this adjustable rack can accommodate a set of differently sized wheels / tyres. Maximum difference in tyre diameters of 65mm.

## Motorcycle Carrying Kit - CT136TA & CT136HD only

Allows one motor cycle to be carried in the centre of the trailer. The kit does not require removal to use trailer for motor vehicle recovery.

## Removable Vehicle Wheel Chock

For vehicles with low ground clearance this feature is invaluable. The wheel stop can be fitted between the wheel and the spoiler AFTER the vehicle is loaded.

## Heavy Duty Wheel Straps

Heavy duty wheel securing straps incorporating soft-link to avoid damage to alloy wheels.

## Lockable Toolbox

Heavy duty, lockable, steel toolbox allows wheel straps and tools to be locked away securely.



Winch mounting kit



Removable vehicle wheel chock



Heavy duty wheel straps and Toolbox

\*Weights refer to maximum weight of rolling vehicle. All winch options have an automatic brake, preventing the vehicle from rolling back if the winch handle is released whilst loading or unloading.

# Beavertail Trailers



Closely related to the flatbed range, but with the addition of a sloping rear bed section, these trailers offer the flexibility of a flatbed with an added benefit of a low loading height<sup>1</sup> to the rear of the trailer.

The beavertail range is offered in width options ranging from: 6' 6" to 7' 6", and length options from 14' to 16' and two maximum gross weight versions, 2000Kg and 3500Kg.

As with all our flatbed trailers the Beavertail can be fitted with many accessories, these include winch, full width loading ramp, loading skids, rear prop stands, headboard and ladder rack.

The beavertail models described here have all the benefits of the regular flatbed range. For full information on the Ifor Williams flatbed range please ask your dealer for the Commercial brochure.



<sup>1</sup> Vehicles with low ground clearance may not be suitable for loading on this type of trailer.



LM166/B with optional propstands

# Beavertail



LM167/B with optional headboard, skids, electric winch, propstands and lashing rings



LM146/B with optional headboard and propstands (lashing straps available as an optional extra)

# Tiltbed Trailers



CT166 with optional drop-sides, headboard and 3' loading ramp



CT166 with optional headboard and 3' loading ramp

For owners of wheeled plant and machinery the Tiltbed is an ideal choice, providing all the benefits of the flatbed range, combined with an easily tilted platform for effortless loading.

There are two size options in the range: 16' long, 6ft' 6" wide and 16' long, 7' 6" wide. Both models offer the maximum gross weight of 3500Kg.

The low tilt angle (approximately 12 degrees) and drop down tail ramp make it easier to drive or winch almost any kind of wheeled vehicle onto the trailer bed. This model is ideally suited to vehicles with differing front to rear wheel track such as specialist ground maintenance equipment and large mowers. A longer (3') loading ramp is also available as an extra cost option to further smooth the transition between the ground and the trailer bed.

Tough, adaptable, and easy to maintain all models are fitted with a tough resin coated plywood platform as standard. A factory fit option of aluminium tread-plate covering is available along with recessed lashing rings. Trailers can be further enhanced by the fitment of accessories such as drop-sides, headboard, ladder rack or mesh side extensions.

The tiltbed models described here have all the benefits of the regular flatbed range. For full information on the Lfor Williams Tiltbed range please ask your dealer for the Commercial brochure.



CT166 with optional 3' loading ramp (1' loading ramp comes as standard)

# Tiltbed

# Beavertail & Tiltbed Standard Dimensions

## Beavertail

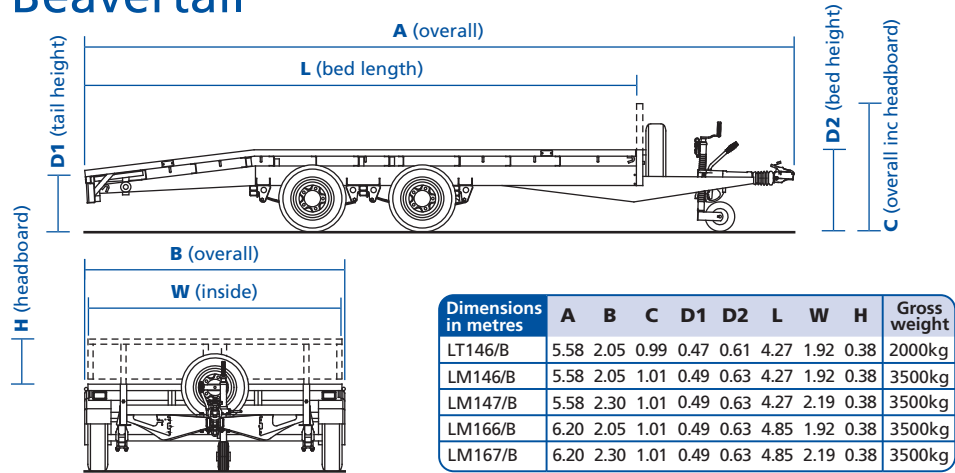

## Tiltbed

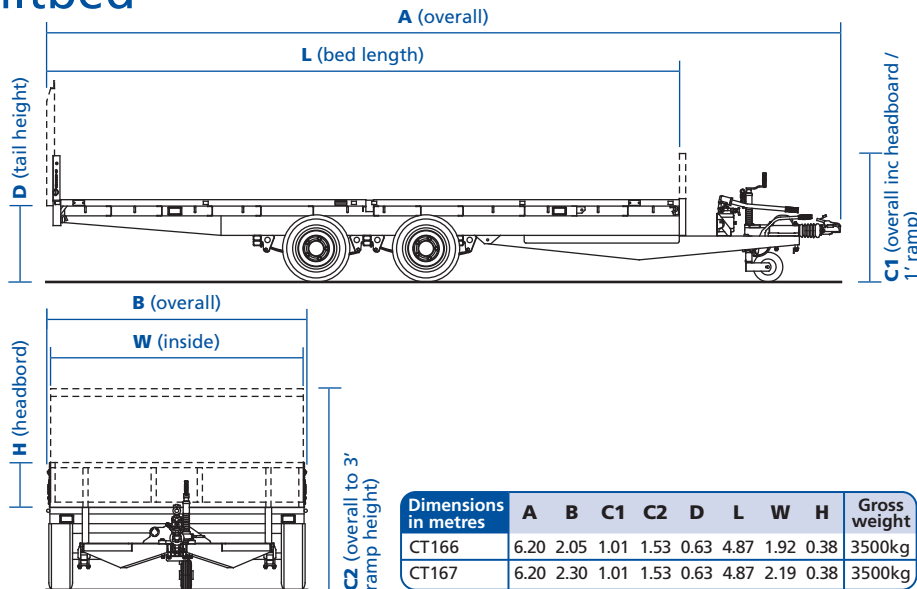

# Beavertail & Tiltbed Options



### Perforated Steel Loading Skids

6' long steel loading ramps. A pair of prop stands are included to support the rear of the trailer when loading. (Beavertail only)



### Lightweight Aluminium Loading Skids

6' long aluminium loading ramps. A pair of prop stands are included to support the rear of the trailer when loading. (Beavertail only)



### Lashing Ring

Recessed hinged ring providing secure floor level fixing point.



### Dropsides

Hinged dropsides increase capacity and contain loose loads such as gravel.



### Floorcovering

Aluminium treadplate.



### Headboard

Provides secure restraint at front of trailer.

# Transporter Specifications

Trailer fitted with Resin Coated Plywood Platform  
 Aluminium Treadplate Platform Covering  
 Removable Headboard Droppides & Tailboard  
 Droppside Fittings  
 Removable Headboard  
 Removable Ladder Rack (Headboard Required)  
 1.8m / 6 Long Perforated Galvanized Steel Skids (Pair) (Including Prop Stands)  
 1.8m / 6 Long Aluminium Skids (Pair) (Including Prop Stands)  
 Weldmesh Panelled Side Extensions  
 Recessed Lashing Ring (Pair)  
 3' Full Width Loading Ramp (Replaces Standard Ramp)  
 6' Full Width Loading Ramp (Replaces Standard Ramp)

## Beavertail Trailers

	Maximum Gross Weight	Tyres												
LT146/B	2000kg	145R10C	•	Option	Option†	Option**	Option	Option	Option	Option	-	Option	-	Option
LM146/B	3500kg	185/60R12C	•	Option	Option†	Option**	Option	Option	Option	Option	-	Option	-	Option
LM147/B	3500kg	185/60R12C	•	Option	Option†	Option**	Option	Option	Option	Option	-	Option	-	Option
LM166/B	3500kg	185/60R12C	•	Option	Option†	Option**	Option	Option	Option	Option	-	Option	-	Option
LM167/B	3500kg	185/60R12C	•	Option	Option†	Option**	Option	Option	Option	Option	-	Option	-	Option

## Tiltbed Trailers

CT166	3500kg	185/60R12C	•	Option	Option*	Std	Option	Option	-	-	Option	Option	Option	-
CT167	3500kg	185/60R12C	•	Option	Option*	Std	Option	Option	-	-	Option	Option	Option	-

\* Excludes tailboard: a standard ramp (1') is included within the trailer price.  
 † Must be specified at time of order, requires droppside fittings.  
 \*\* Droppside Fittings must be specified at time of order, factory fit only.

Basic Trailer  
 Spare Wheel & Bracket  
 Centre Decking  
 Softlink Adjustable Wheel Straps (Pair)  
 Vehicle Wheel Chocks (Pair)  
 Heavy Duty Lockable Steel Toolbox  
 Winch Mounting Kit  
 GM5 Strap Winch (Manual)  
 GM5 Cable Winch (Manual)  
 3T Strap Winch (Manual)  
 3T Cable Winch (Manual)  
 E40 Cable Winch (Electric)  
 E40 Cable Winch with Battery (Electric)  
 Circuit 600kg Mechanical Cable Winch  
 Rally 1050kg Mechanical Cable Winch  
 Recovery 1500kg Mechanical Cable Winch  
 Tyre Rack - Cranked Bar  
 Tyre Rack - Straight Bar  
 Motorcycle Carrying Kit  
 Ski Jump Kit

## Car Transporter Trailers

CT115 (single axle)	1400kg	155/70R12C	•	Option	-	Option	Option	Option	Option	-	-	-	-	-	-	Option	Option	Option	Option	Option	-	-
CT136SA (single axle)	1400kg	155/70R12C	•	Option	-	Option	Option	Option	Option	-	-	-	-	-	-	Option	Option	Option	Option	Option	-	-
CT136TA (twin axle)	2000kg	155/70R12C	•	Option	-	Option	Option	Option	Option	-	-	-	-	-	-	Option	Option	Option	Option	Option	Option	-
CT136HD (twin axle)	2600kg	155/70R12C	•	Option	-	Option	Option	Option	Option	-	-	-	-	-	-	Option	Option	Option	Option	Option	Option	-
CT177	3500kg	155/70R12C	•	Std	Option	Option	Option	Std	Std	Option	Option	Option	Option	Option	Option	-	-	-	-	-	-	Option

All trailers are twin axle unless stated otherwise. Coupling locks and wheel clamps can be supplied for all trailer models. Prices on application.

Dimensions and weights are given as a guide only. We reserve the right to alter specifications without notice.

Optional accessories have been priced as factory fit items, ordered with your trailer. If ordered at a later date, your distributor may need to fit the items, which will result in fitting charges being incurred.



CT177 with optional winch

Product design, descriptions, colours, specifications etc. correct at time of going to press. We constantly strive to improve our products, and from time to time this may result in changes to our range or to individual models. Please check that design, description, colours, specifications described in this brochure are still valid at the time of placing an order.

Our distributors have extensive product knowledge and will be pleased to offer assistance in the selection of your trailer.

© Ifor Williams Trailers Ltd 2007.  
All rights reserved.

No part of this publication may be reproduced in any form or by any means, without the prior written permission of Ifor Williams Trailers Ltd.

Distributed throughout the UK & Europe



### Ifor Williams Trailers Ltd

Cynwyd, Corwen, Denbighshire LL21 0LB UK

Telephone +44 (0)1490 412527

Facsimile +44 (0)1490 413216

For further information visit our  
comprehensive website

[www.iwt.co.uk](http://www.iwt.co.uk)